

**HOUSING + STRAIGHT MALE JACK**  
**CRIMP TYPE CABLE 2.6/50S PACK500**

**R197.134.C00**

Series : SMB  
**CARLOCK**

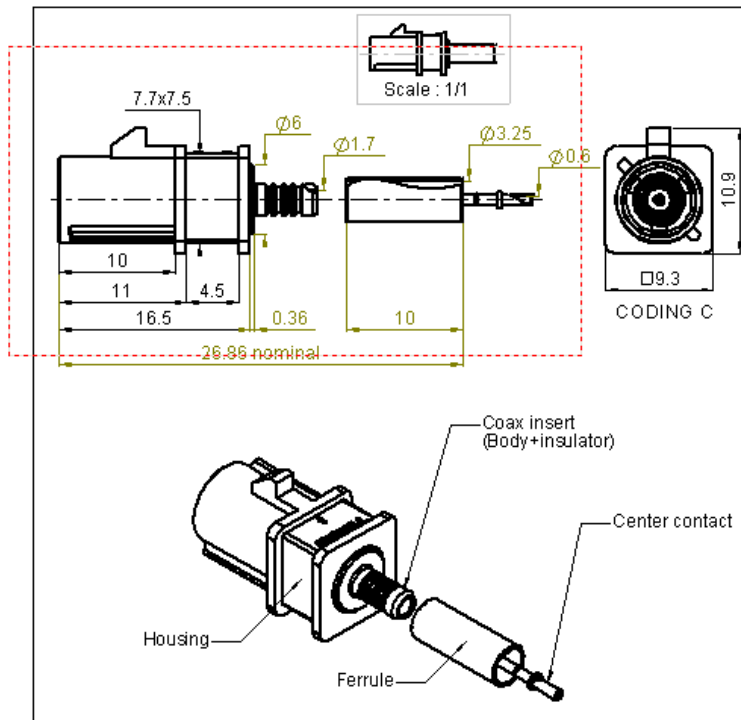

All dimensions are in mm.

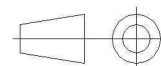

COMPONENTS	MATERIALS	PLATINGS (µm)				
BODY	BRASS	NICKEL 2				
CENTER CONTACT	BRASS	GOLD 0.8 OVER NICKEL 2				
OUTER CONTACT	-	-				
INSULATOR	PTFE					
GASKET	-					
OTHERS PARTS	BRASS	NICKEL 2				
HOUSING	PA6.6 GF15 (POLYAMIDE)	<table border="1"> <tr> <th>UL CLASSIFICATION</th> <th>COLOR</th> </tr> <tr> <td>UL 94 V-2</td> <td>BLUE RAL 5005</td> </tr> </table>	UL CLASSIFICATION	COLOR	UL 94 V-2	BLUE RAL 5005
UL CLASSIFICATION	COLOR					
UL 94 V-2	BLUE RAL 5005					

Issue : 0737 B

In the effort to improve our products, we reserve the right to make changes judged to be necessary.



**HOUSING + STRAIGHT MALE JACK**  
**CRIMP TYPE CABLE 2.6/50S PACK500**

**R197.134.C00**  
Series : **SMB**  
**CARLOCK**

**PACKAGING**

Standard	Unit	Other
<b>500</b>	<b>'W' option</b>	<b>Contact us</b>

**ELECTRICAL CHARACTERISTICS**

Impedance	<b>50</b>	$\Omega$
Frequency	<b>0-4</b>	GHz
VSWR	<b>1.20 + 0,0000</b>	x F(GHz) Maxi
Insertion loss	<b>0.05</b>	$\sqrt{F}$ (GHz) dB Maxi
RF leakage	<b>-45</b>	- F(GHz)) dB Maxi
Voltage rating	<b>335</b>	Veff Maxi
Dielectric withstanding voltage	<b>1000</b>	Veff mini
Insulation resistance	<b>1000</b>	M $\Omega$ mini

**MECHANICAL CHARACTERISTICS**

Center contact retention		
Axial force – Mating end	<b>10</b>	N mini
Axial force – Opposite end	<b>10</b>	N mini
Torque	<b>NA</b>	N.cm mini

Recommended torque		
Mating	<b>NA</b>	N.cm
Panel nut	<b>NA</b>	N.cm
Clamp nut	<b>NA</b>	N.cm
A/F clamp nut	<b>0,0000</b>	mm

Mating life	<b>100</b>	Cycles mini
Weight	<b>2,5591</b>	g

**ENVIRONMENTAL**

Operating temperature	<b>-40/+110</b>	$^{\circ}$ C
Hermetic seal	<b>NA</b>	Atm.cm3/s
Panel leakage	<b>NA</b>	

**SPECIFICATION**

SAE/USCAR-17 Rev.1 (October 2002)  
SAE/USCAR-2 Rev.3 (February 2001)  
SAE/USCAR-18 Rev.2 (January 2003)

**CABLE ASSEMBLY**

Stripping	a	b	c	d	e	f
mm	2,40	5,50	10,2	0,00	7,80	0,00

Assembly instruction : **Pages 4 & 5**

Recommended cable(s)  
RG 174  
RG 316

Characteristics indicated on this data sheet are those that can be achieved with the highest performance cable. Intrinsic limitations of the cable may diminish the performance of the assembly

Cable retention

- pull off	<b>RG174 JUDD CABLE</b>	<b>110 N mini</b>
	<b>RG316</b>	<b>110 N mini</b>
	<b>RG174</b>	<b>65* N mini</b>
		<b>NA N.cm</b>

**TOOLING**

Part Number	Description	Hexagon
.	.	.
R282.293.000	CRIMPING TOOL M22520/5-01	
R282.235.915	CRIMPING DIES	Hex 3.25 Square 0.72
R282.271.000	CRIMPING TOOL	Hex 3.25 Square 0.72
R282.281.000	CRIMPING TOOL	2x4pts 3pos
R282.967.034	POSITIONER FOR TOOL R282 281	

**OTHERS CHARACTERISTICS**

Depends on the cable used  
VSWR : 1.20 maxi at 4GHz

Issue : 0737 B

In the effort to improve our products, we reserve the right to make changes judged to be necessary.





**HOUSING + STRAIGHT MALE JACK**

**CRIMP TYPE CABLE 2.6/50S PACK500**

**R197.134.C00**

Series : SMB  
CARLOCK

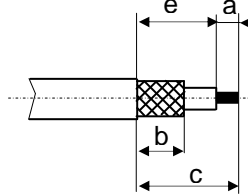
**Recommended mounting procedure for RG174 cable**

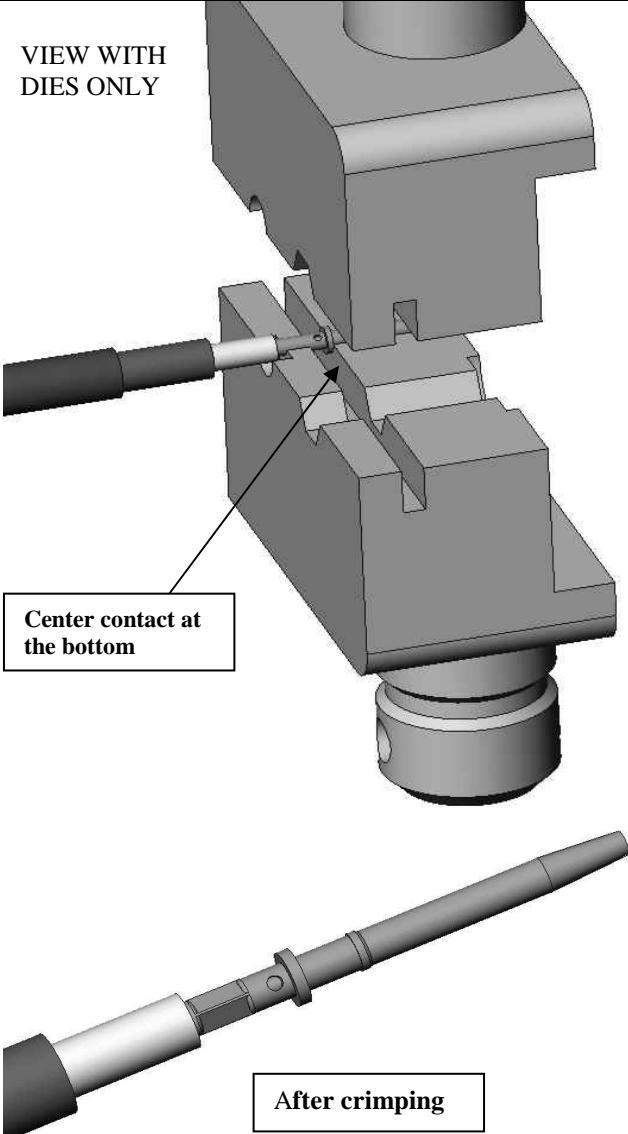
	
<p><b>1</b></p> <ul style="list-style-type: none"> <li>• Slide the ferrule onto the cable</li> <li>• Strip the cable</li> </ul>	
<p><b>2</b></p> <ul style="list-style-type: none"> <li>• Slide the centre contact on until it bottoms against the cable dielectric</li> <li>• Crimp the centre contact with crimping tool R282.293.000 (M22520/5-01) + dies R282.235.915 (square 0.72) or R282.281.000 (3 position) (2x4pts) with positioner R282.967.034.</li> </ul>	<p>VIEW WITH DIES ONLY</p> 

Issue : 0737 B

In the effort to improve our products, we reserve the right to make changes judged to be necessary.



**RADIALL**®

**HOUSING + STRAIGHT MALE JACK**

**R197.134.C00**

**CRIMP TYPE CABLE 2.6/50S PACK500**

Series : SMB  
CARLOCK

**Recommended mounting procedure for RG174 cable**

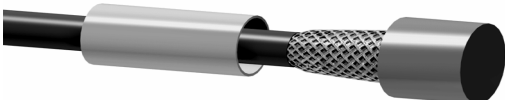
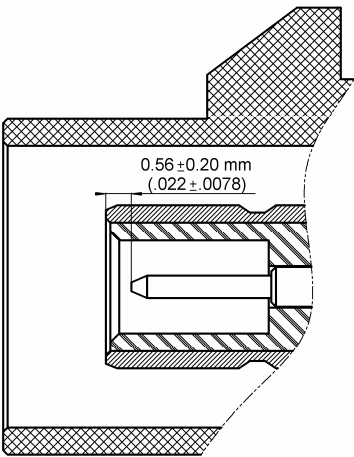
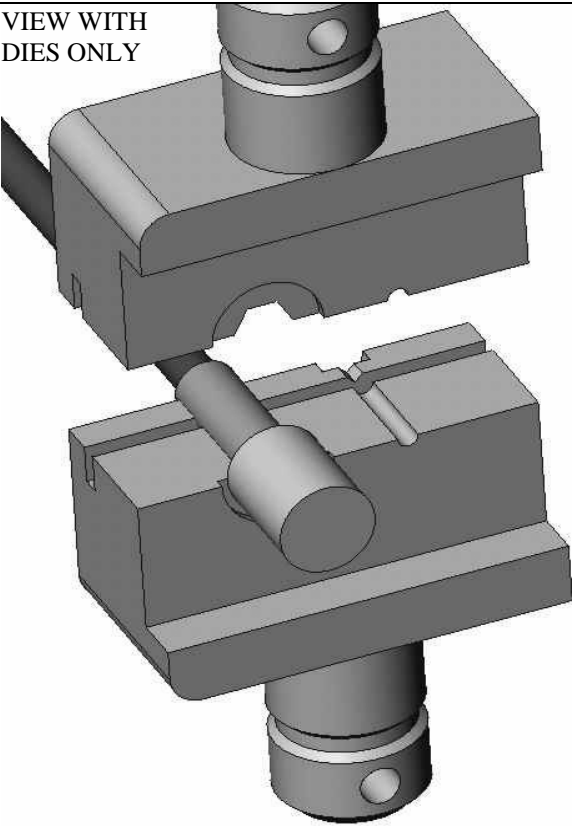
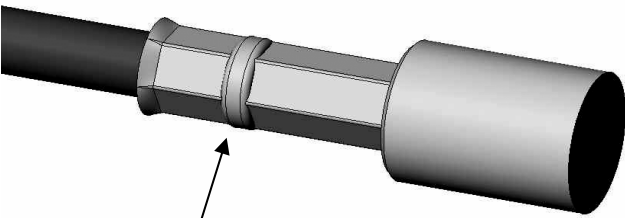
<p><b>3</b></p> <ul style="list-style-type: none"> <li>• Fan the braid</li> </ul>	
<p><b>4</b></p> <ul style="list-style-type: none"> <li>• Slide the cable into the body until it bottoms against insulator</li> </ul>	
<p><b>5</b></p> <ul style="list-style-type: none"> <li>• Slide the ferrule over the braid</li> <li>• Crimp the ferrule as shown on the picture with crimping tool R282.293.000 (M22520/5-01) + dies R282.235.915 (Double crimping Hex 3.25).</li> <li>• Check the position of the center contact between the top of the body and the top of the center contact : <math>0.56 \pm 0.20</math> mm (<math>.022 \pm .0078</math>).</li> </ul> 	<p>VIEW WITH DIES ONLY</p>   <p>Right tool orientation :after crimping the bump must be closer to the cable than to the body</p>

Issue : 0737 B

In the effort to improve our products, we reserve the right to make changes judged to be necessary.

